

Opp. ruwheid (zie NEN 3634)	Maattoleranties NEN-ISO 2768-	MATERIAAL:Staal	Vorm- en plaatstol. (zie NEN-ISO11010)
	SCHAAL:1:1	GETEKEND:Weithai Liu	OPMERKING:
	MAATEENHEID: mm	AFDELING:	
	DATUM:6-06-2021	GEZIEN:	BENAMING:Foldable BBQ
			

Puntlassen of TIG/MIG lassen

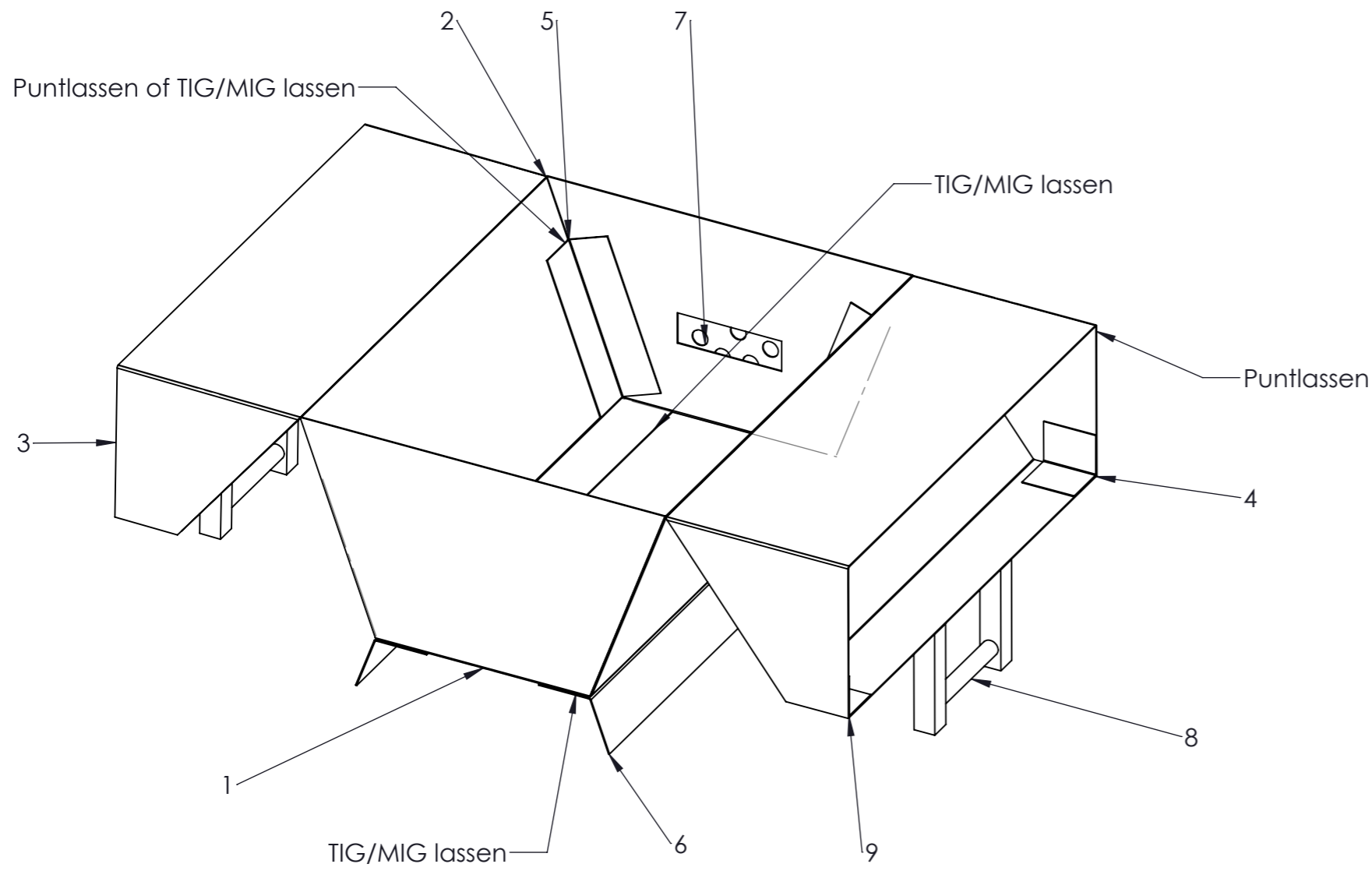

TIG/MIG lassen

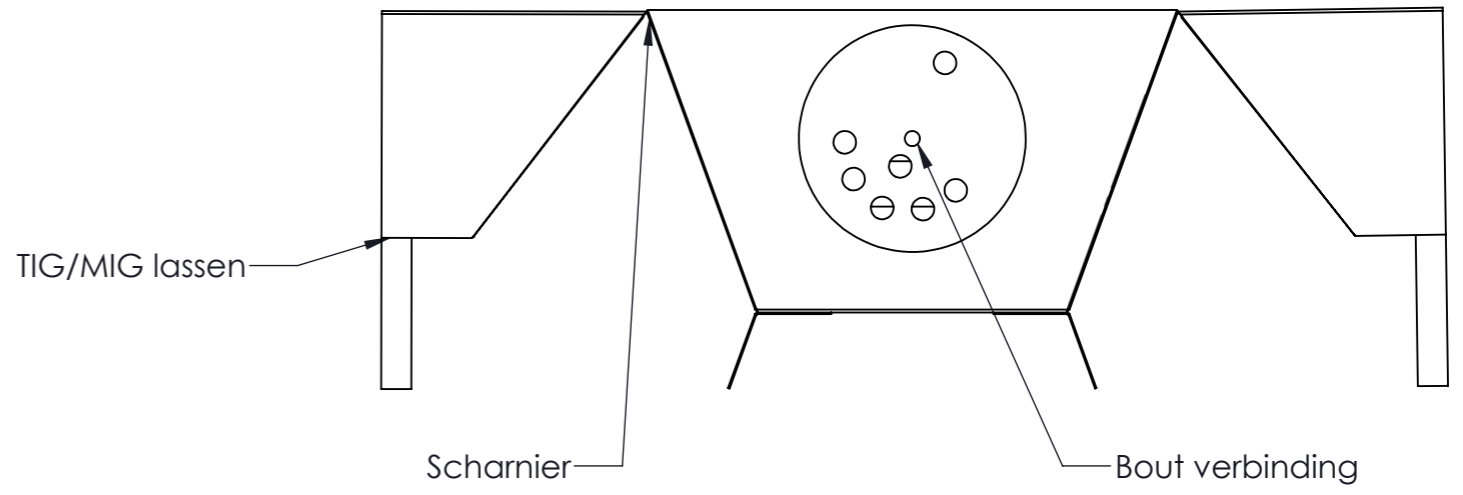

ITEM NO.	PART NUMBER	QTY.
1	BBQ base	1
2	BBQ base deel 2	2
3	BBQ uitklapbare deksel deel 1	2
4	BBQ uitklapbare deksel deel 2	2
5	Verbindingsstrip lang	4
6	BBQ poten	2
7	Luchtregelaar	1
8	BBQ handvat	2
9	Verbindingsstrip	4

Opp. ruwheid (zie NEN 3634)	Maattoleranties NEN-ISO 2768-	MATERIAAL:Staal	Vorm- en plaatstol. (zie NEN-ISO11010)
	SCHAAL:1:1	GETEKEND:Weithai Liu	OPMERKING:
	MAATEENHEID: mm	AFDELING:	
	DATUM:6-06-2021	GEZIEN:	BENAMING:Foldable BBQ
			A3

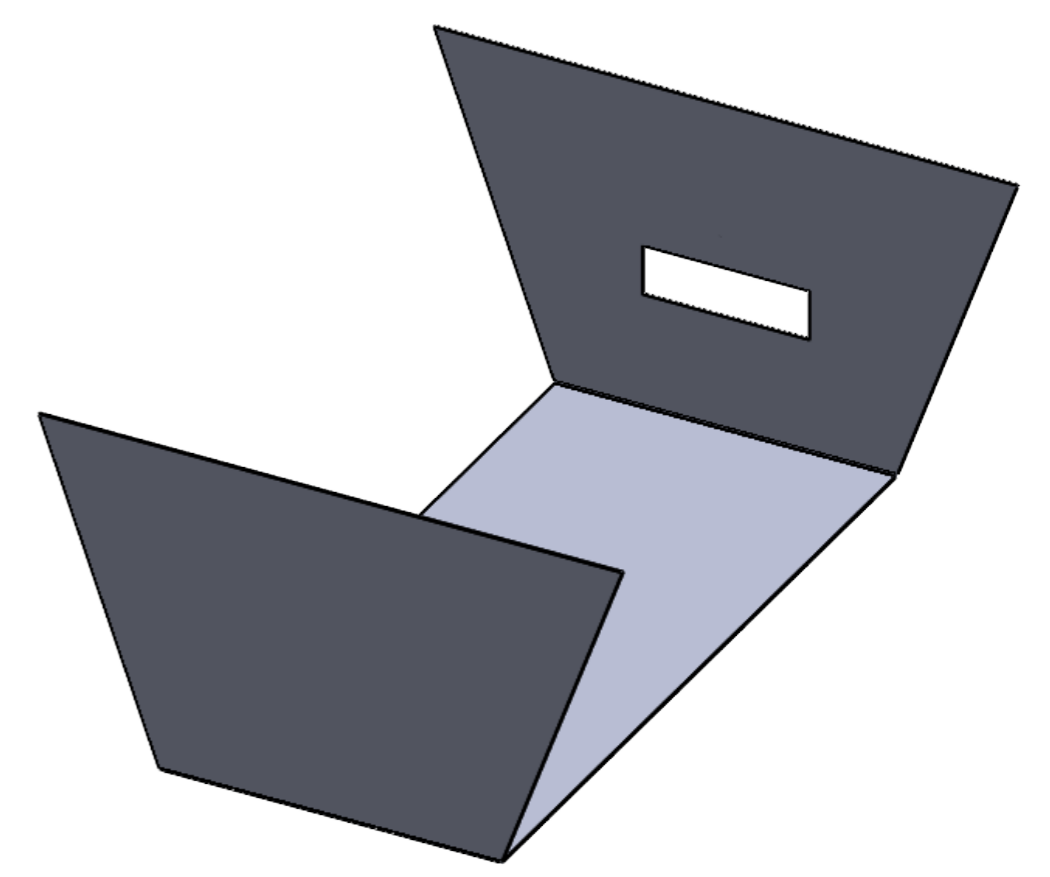
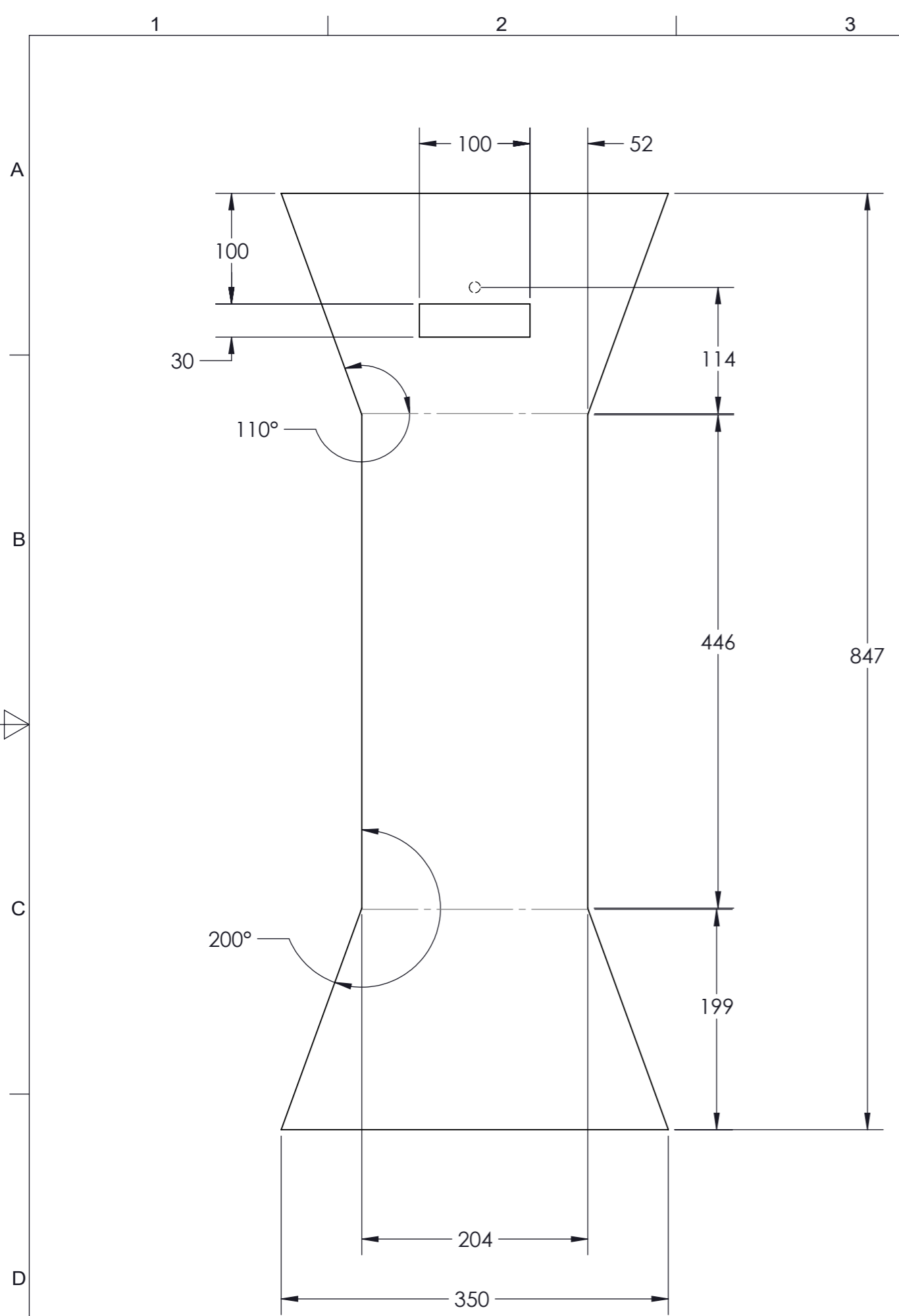

1 x

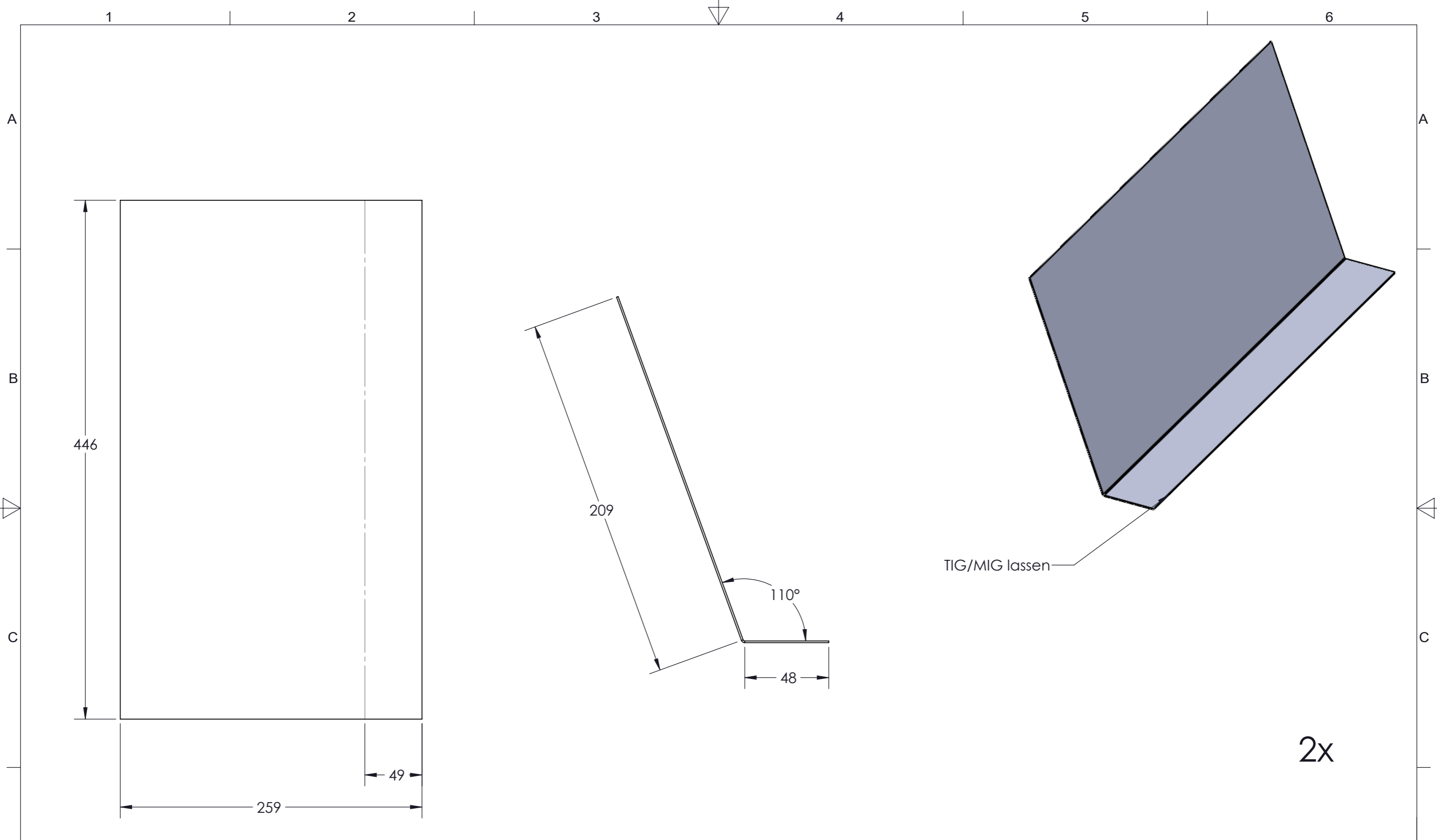

Opp. ruwheid (zie NEN 3634)	Maattoleranties NEN-ISO 2768-	MATERIAAL:Staal	Vorm- en plaatstol. (zie NEN-ISO11010)
	SCHAAL:1:1	GETEKEND:Weithai Liu	OPMERKING:
	MAATEENHEID: mm	AFDELING:	
	DATUM:6-06-2021	GEZIEN:	
		BENAMING:Foldable BBQ	NUMMER: A3

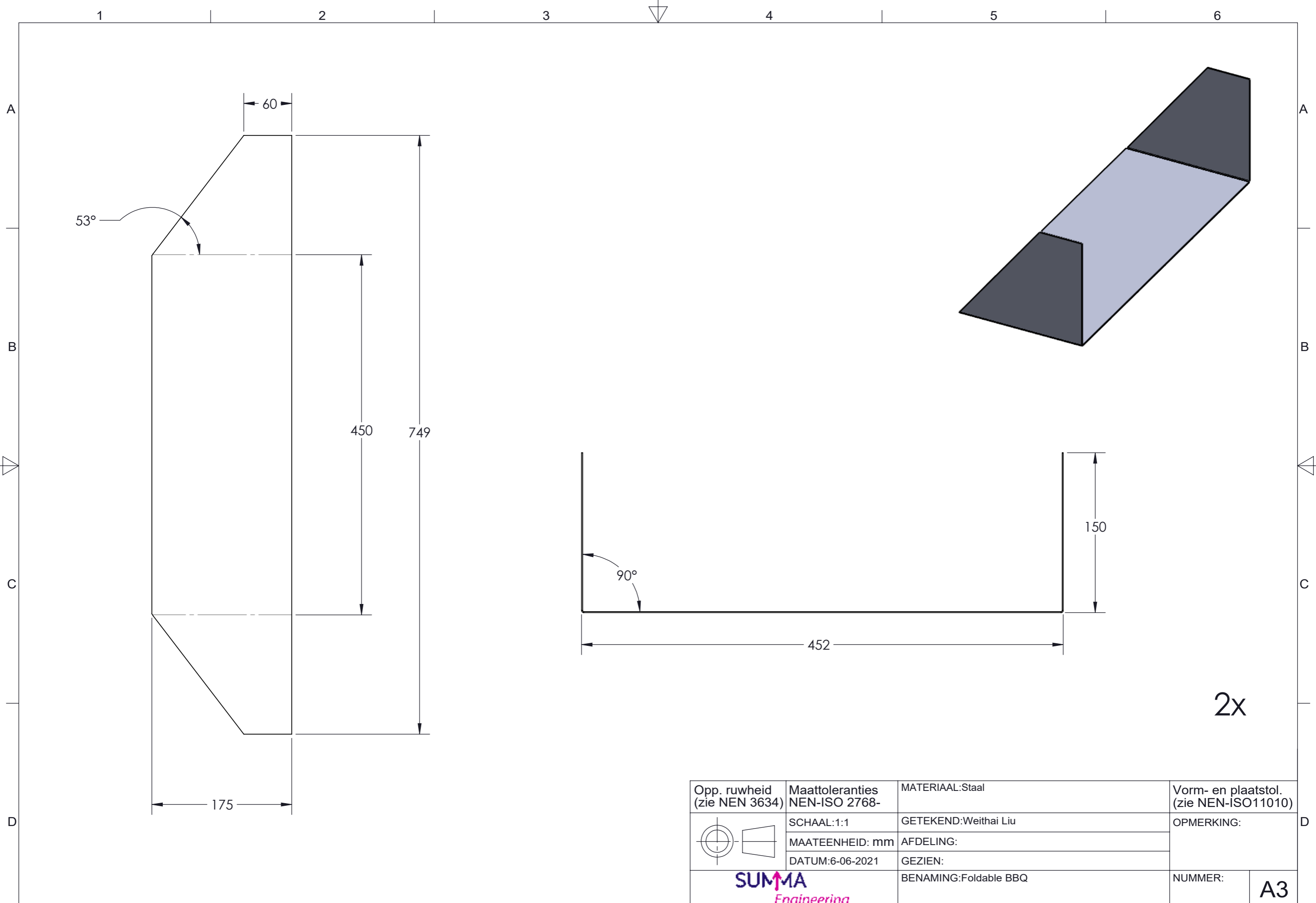

Opp. ruwheid (zie NEN 3634)	Maattoleranties NEN-ISO 2768-	MATERIAAL:Staal	Vorm- en plaatstol. (zie NEN-ISO11010)
	SCHAAL:1:1	GETEKEND:Weithai Liu	OPMERKING:
	MAATEENHEID: mm	AFDELING:	
	DATUM:6-06-2021	GEZIEN:	
		BENAMING:Foldable BBQ	NUMMER: A3

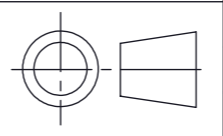

2x

Opp. ruwheid (zie NEN 3634)	Maattoleranties NEN-ISO 2768-	MATERIAAL:Staal	Vorm- en plaatstol. (zie NEN-ISO11010)
	SCHAAL:1:1	GETEKEND:Weithai Liu	OPMERKING:
	MAATEENHEID: mm	AFDELING:	
	DATUM:6-06-2021	GEZIEN:	BENAMING:Foldable BBQ
			A3

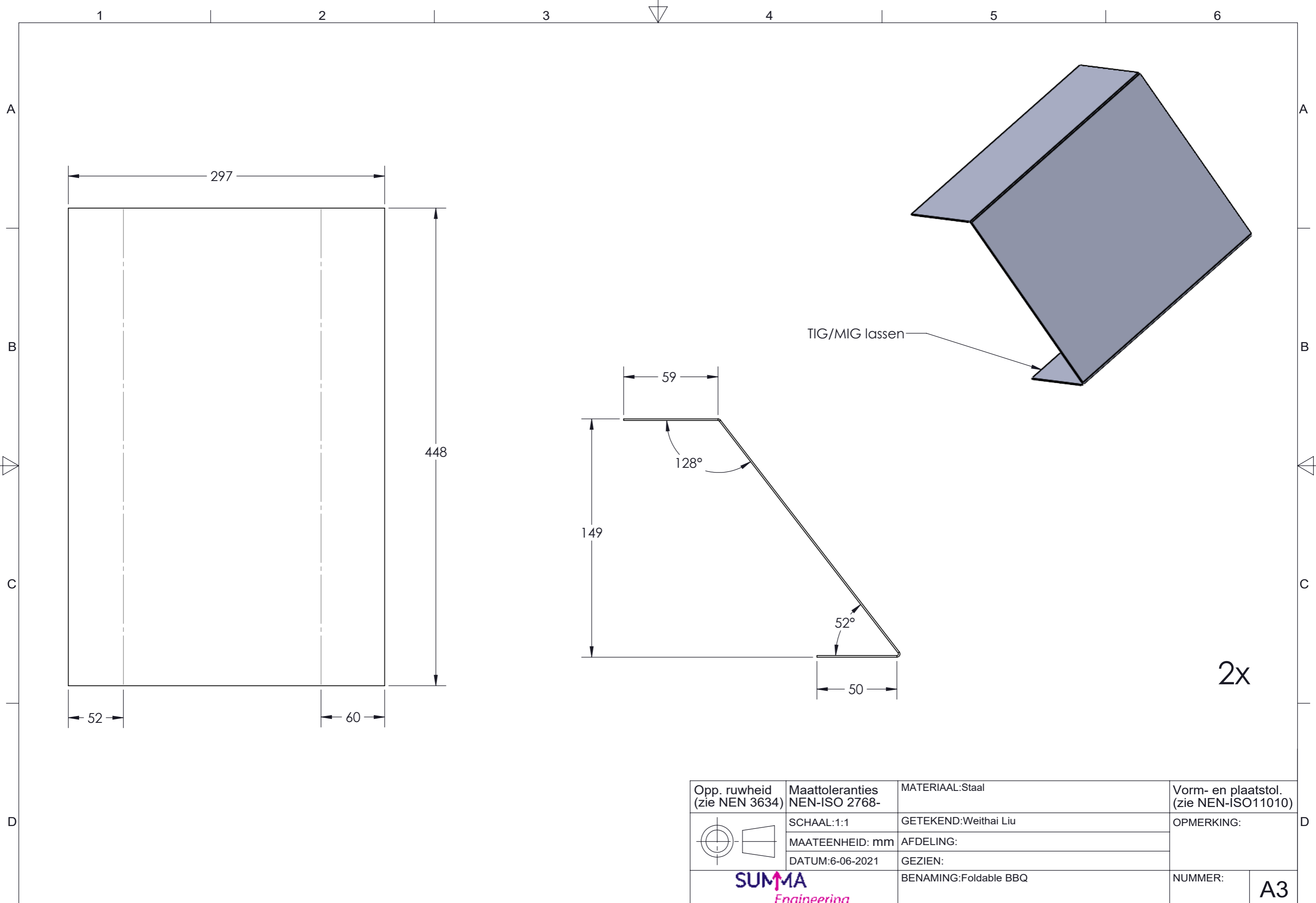

Opp. ruwheid (zie NEN 3634)	Maattoleranties NEN-ISO 2768-	MATERIAAL:Staal	Vorm- en plaatstol. (zie NEN-ISO11010)
	SCHAAL:1:1	GETEKEND:Weithai Liu	OPMERKING:
	MAATEENHEID: mm	AFDELING:	
	DATUM:6-06-2021	GEZIEN:	BENAMING:Foldable BBQ
			A3

1 2 3 4 5 6

A

A

B

B

C

C

D

D

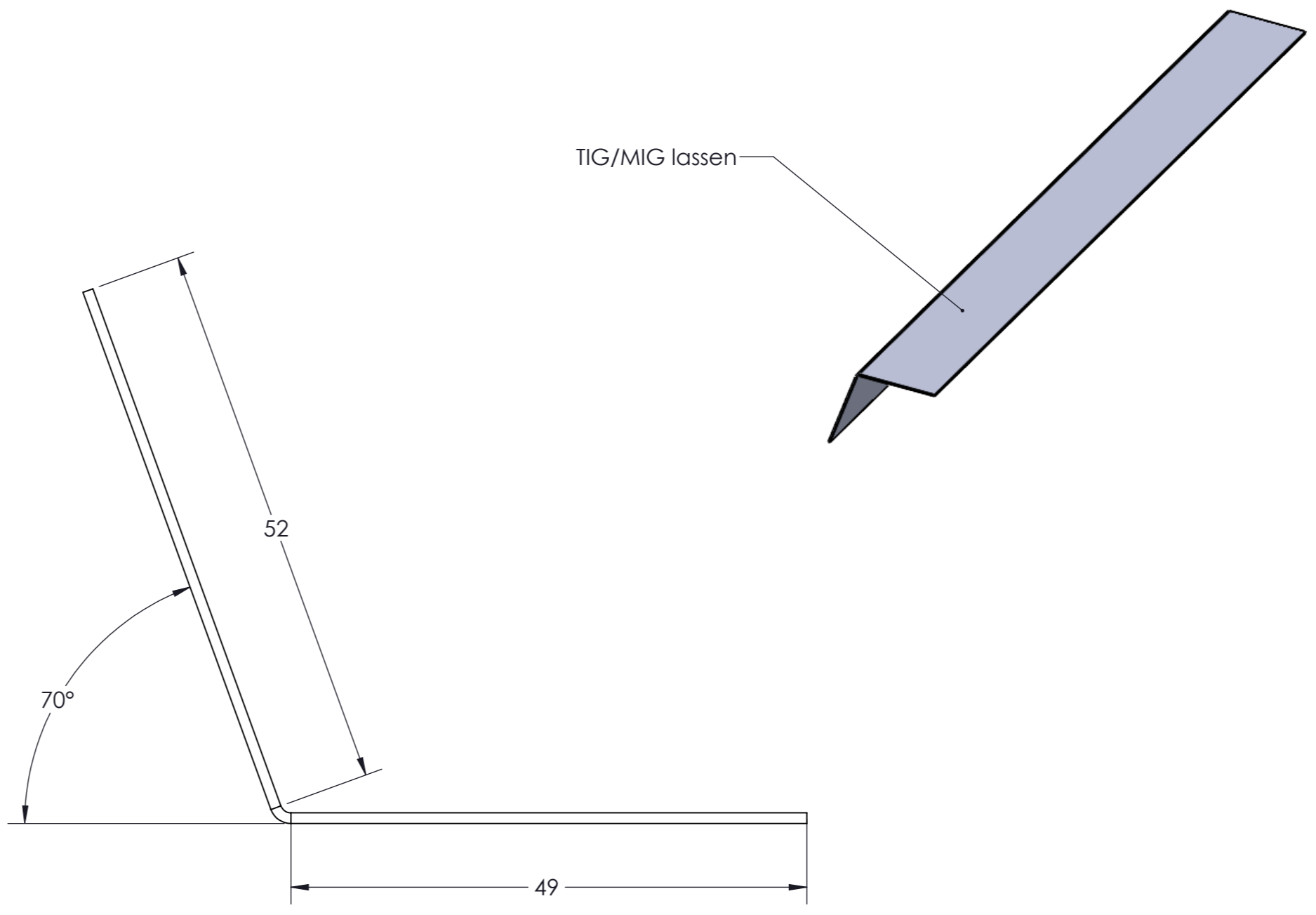
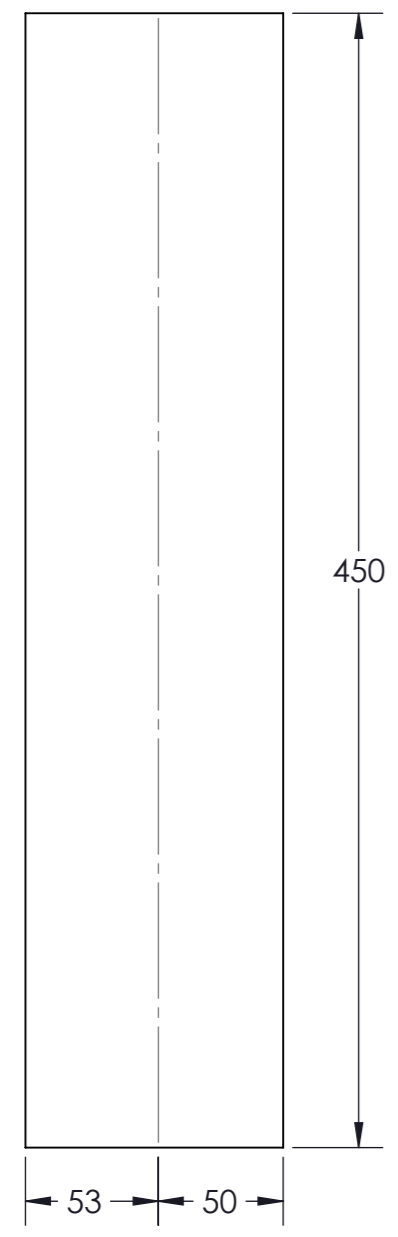

2x

Opp. ruwheid (zie NEN 3634)	Maattoleranties NEN-ISO 2768-	MATERIAAL:Staal	Vorm- en plaatstol. (zie NEN-ISO11010)
	SCHAAL:1:1	GETEKEND:Weithai Liu	OPMERKING:
	MAATEENHEID: mm	AFDELING:	
	DATUM:6-06-2021	GEZIEN:	
		BENAMING:Foldable BBQ	NUMMER: A3

1 2 3 4 5 6

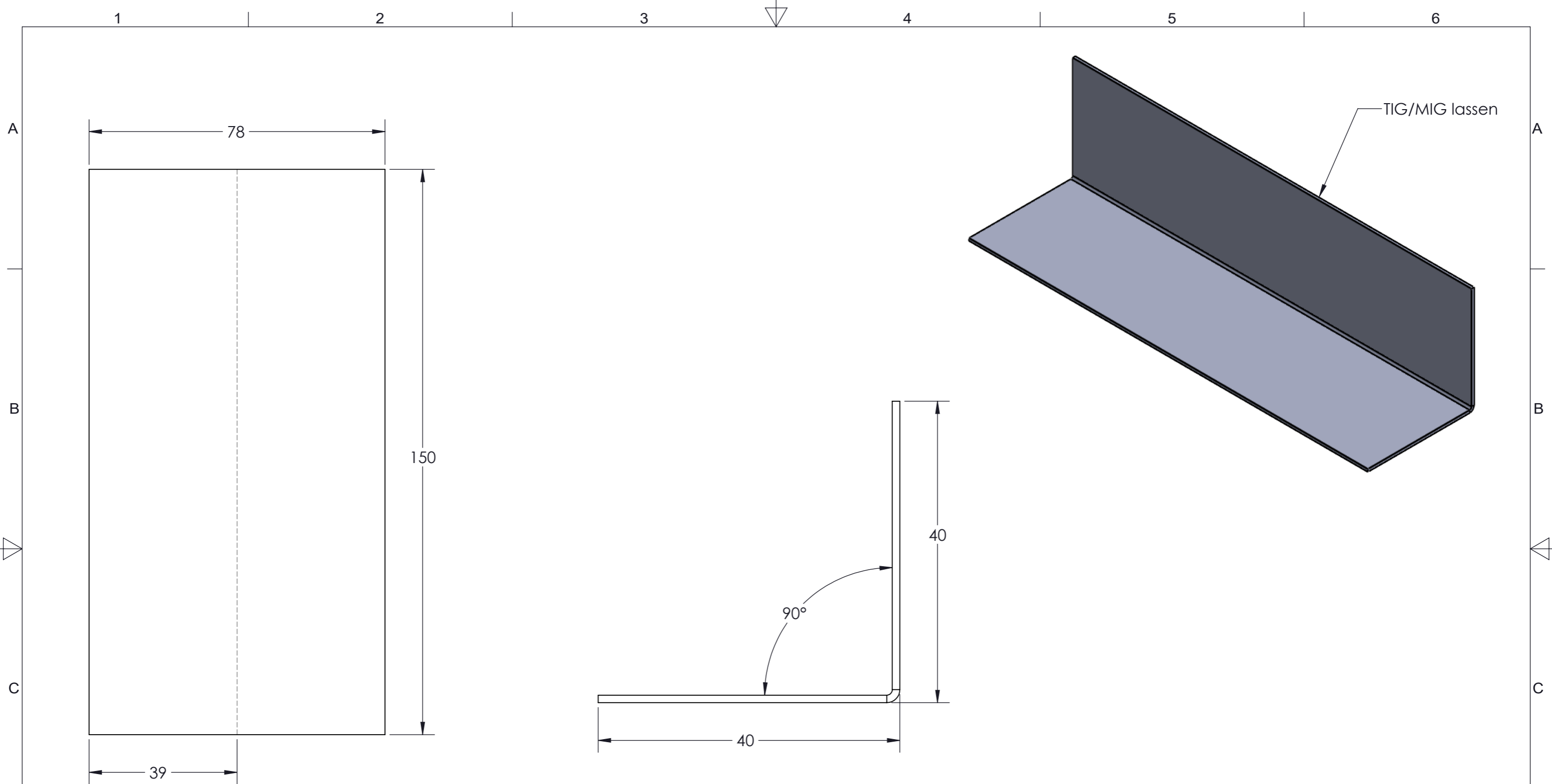

4x

Opp. ruwheid (zie NEN 3634)	Maattoleranties NEN-ISO 2768-	MATERIAAL:Staal	Vorm- en plaatstol. (zie NEN-ISO11010)
	SCHAAL:1:1	GETEKEND:Weithai Liu	OPMERKING:
	MAATEENHEID: mm	AFDELING:	
	DATUM:6-06-2021	GEZIEN:	
		BENAMING:Foldable BBQ	NUMMER: A3

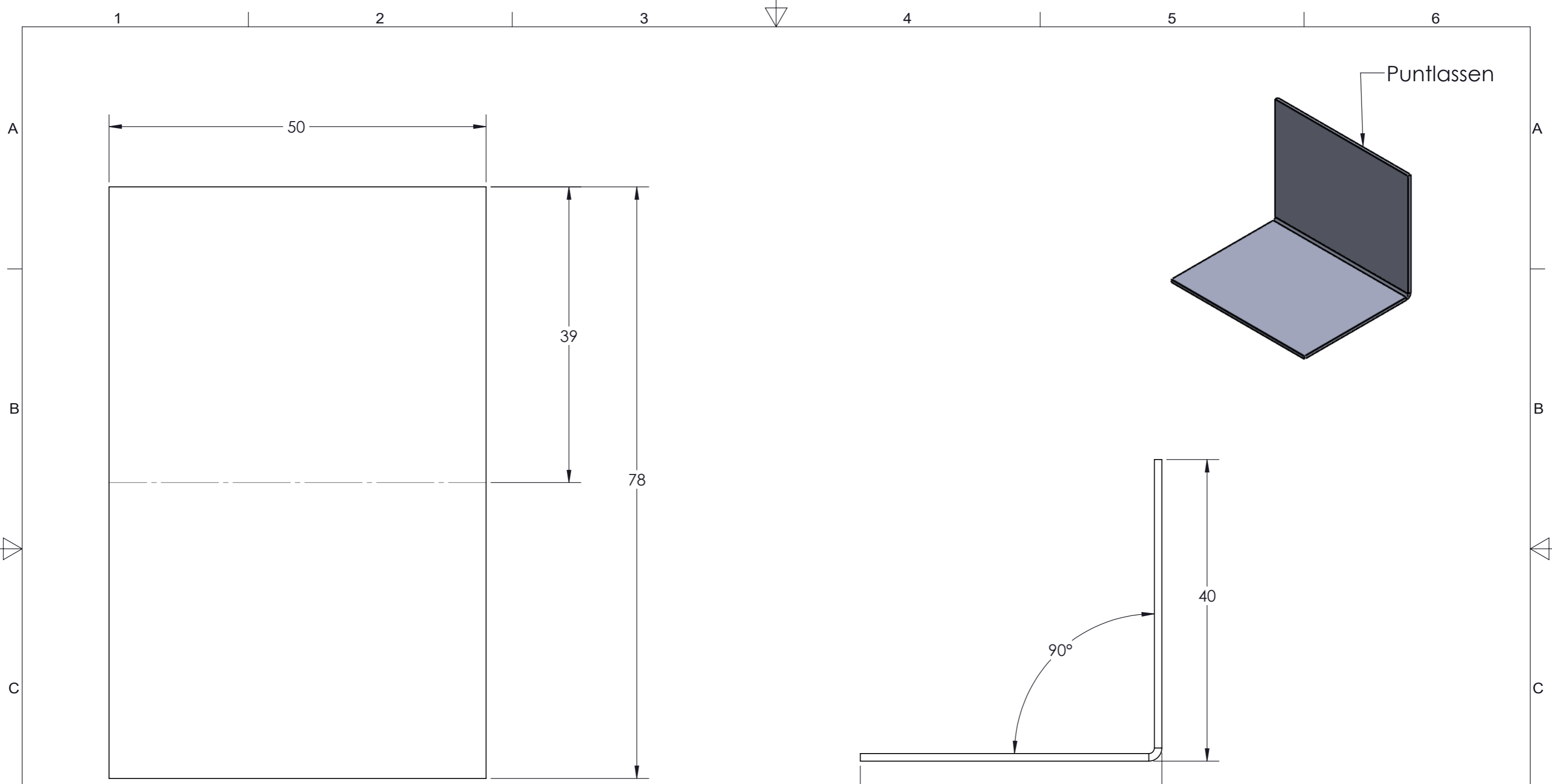

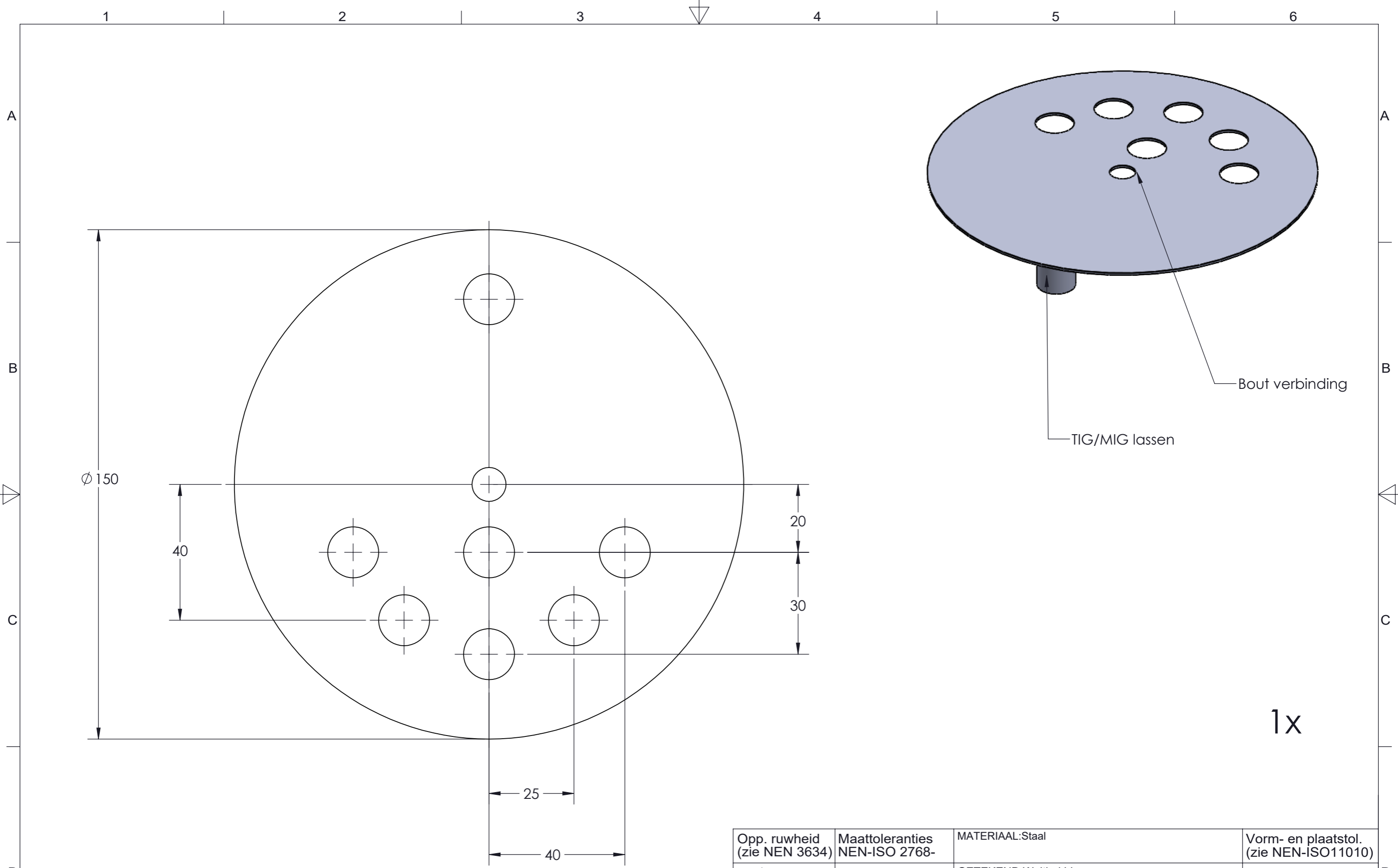

4x

Opp. ruwheid (zie NEN 3634)	Maattoleranties NEN-ISO 2768-	MATERIAAL:Staal	Vorm- en plaatstol. (zie NEN-ISO11010)
	SCHAAL:1:1	GETEKEND:Weithai Liu	OPMERKING:
	MAATEENHEID: mm	AFDELING:	
	DATUM:6-06-2021	GEZIEN:	BENAMING:Foldable BBQ

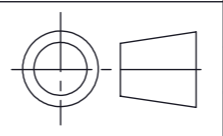

1x

Opp. ruwheid (zie NEN 3634)	Maattoleranties NEN-ISO 2768-	MATERIAAL:Staal	Vorm- en plaatstol. (zie NEN-ISO11010)
	SCHAAL:1:1	GETEKEND:Weithai Liu	OPMERKING:
	MAATEENHEID: mm	AFDELING:	
	DATUM:6-06-2021	GEZIEN:	
		BENAMING:Foldable BBQ	NUMMER: A3

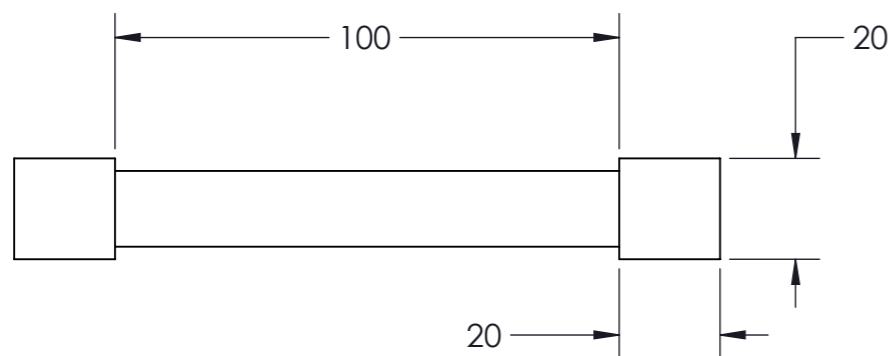
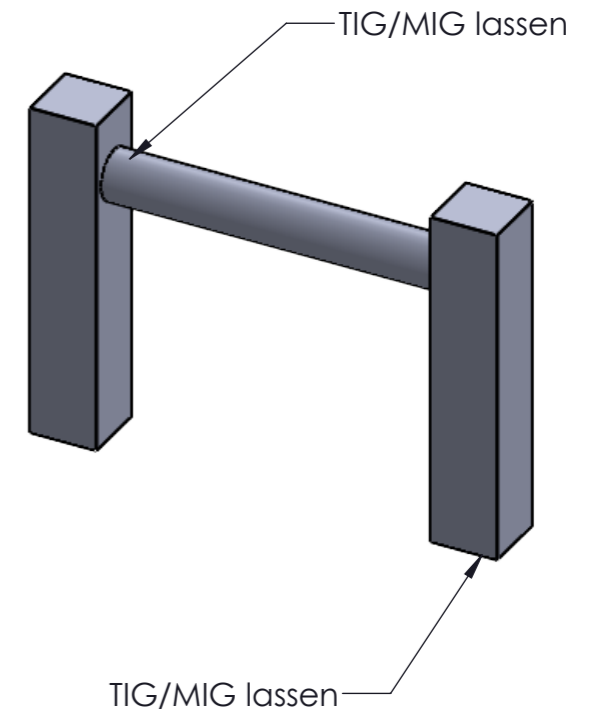
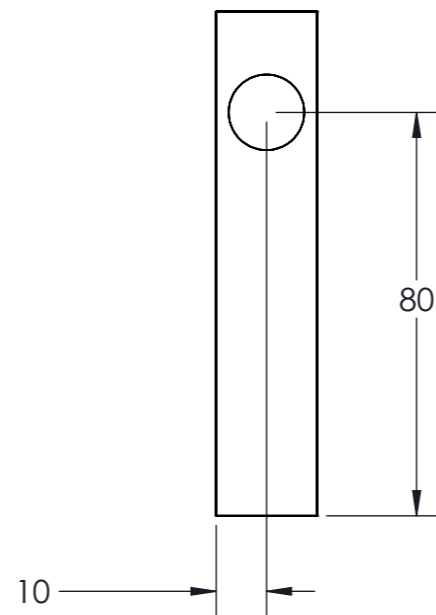
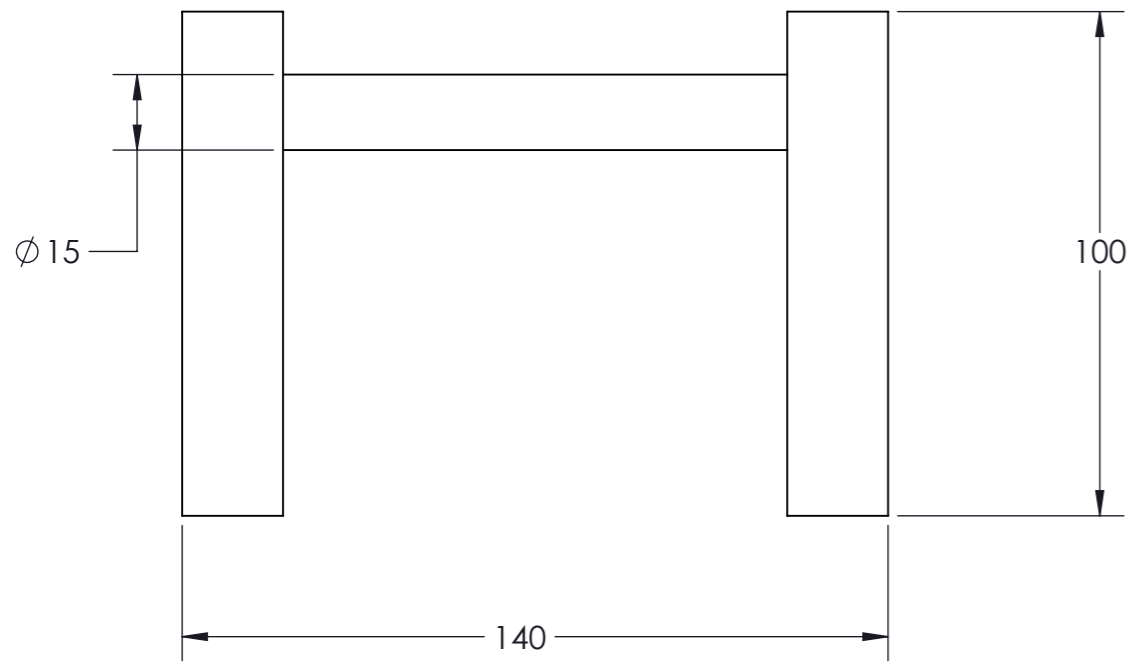

Maten kunnen verschillen

2x

Opp. ruwheid (zie NEN 3634)	Maattoleranties NEN-ISO 2768-	MATERIAAL:Staal	Vorm- en plaatstol. (zie NEN-ISO11010)
	SCHAAL:1:1	GETEKEND:Weithai Liu	OPMERKING:
	MAATEENHEID: mm	AFDELING:	
	DATUM:6-06-2021	GEZIEN:	BENAMING:Foldable BBQ